

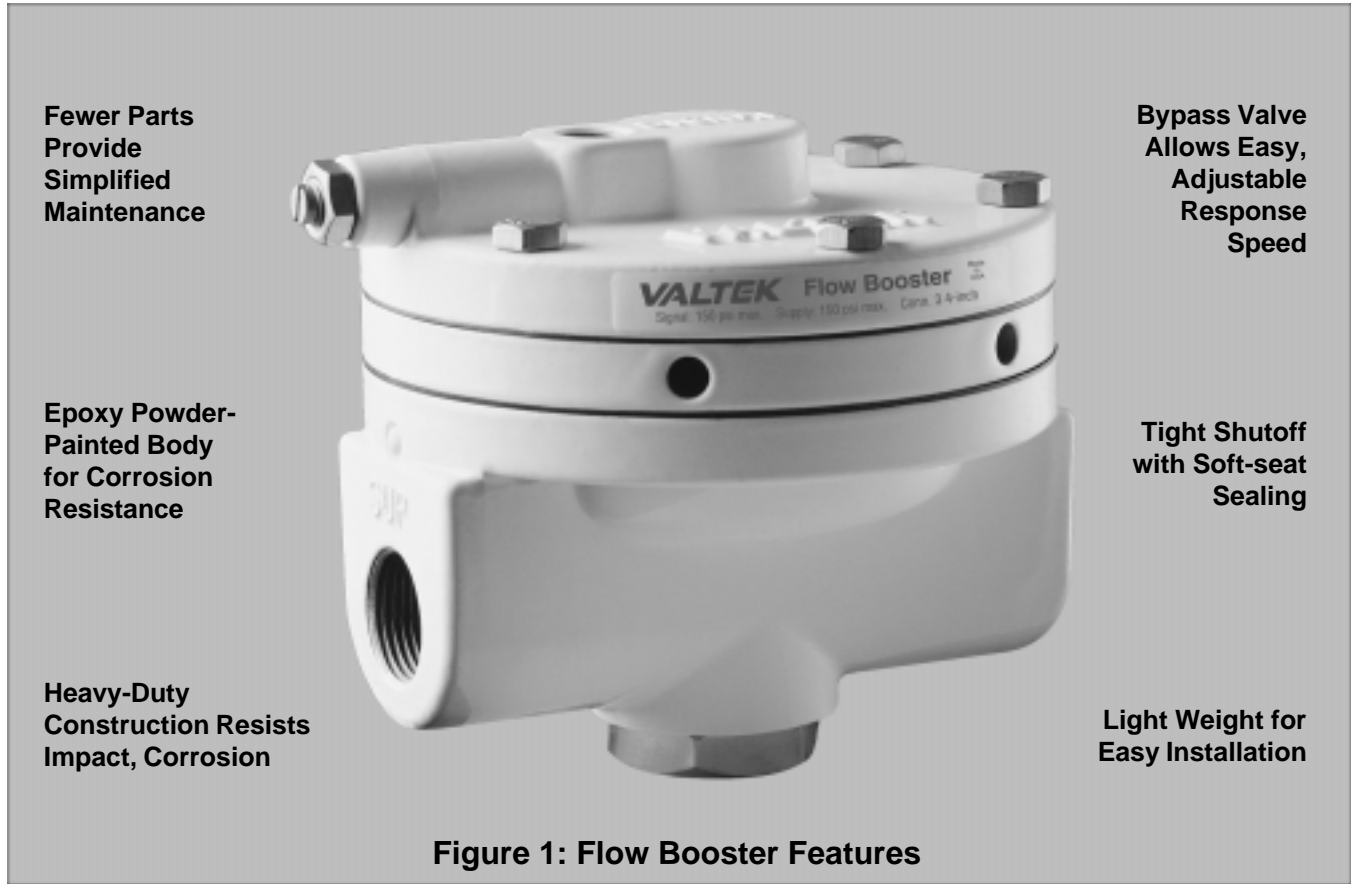

Valtek Flow Boosters

Valtek Flow Booster

Design Features



Introduction

The Valtek® Flow Booster is a one-to-one pressure regulator that amplifies flow to increase the stroking speed of actuators.

Boosters are generally used in conjunction with throttling, control-valve positioners to provide fast action with large input signal changes. The booster allows normal positioner air flow and normal actuation with small input-signal changes. This variation in air flow is accomplished with an internal bypass valve that is adjusted to obtain the desired speed, while maintaining dynamic stability.

Booster Operation

The booster is a pressure-balanced instrument that responds to large input signal changes. Adjusting the bypass valve will either increase or decrease the booster's sensitivity to a signal change. A small input signal to the booster will not create a pressure differential across the

diaphragm assembly sufficient to cause booster actuation. Rather, the air passes through the bypass porting while the poppet valve remains tightly shut to prevent instability. A sudden, large input signal change will create a pressure differential across the diaphragm assembly, forcing the poppet down and permitting high air flow into the control valve actuator.

This high air flow continues until the pressure difference between the control valve actuator and the input signal falls within the dead band limits of the booster. Likewise, when the booster is used to exhaust a control valve actuator, the pressure imbalance across the diaphragm assembly forces it up off the upper poppet valve and the air exits the booster between the diaphragms. For on / off control valves, the bypass valve can be nearly closed to optimize stroking speed.

Valtek Flow Booster

Features and Advantages

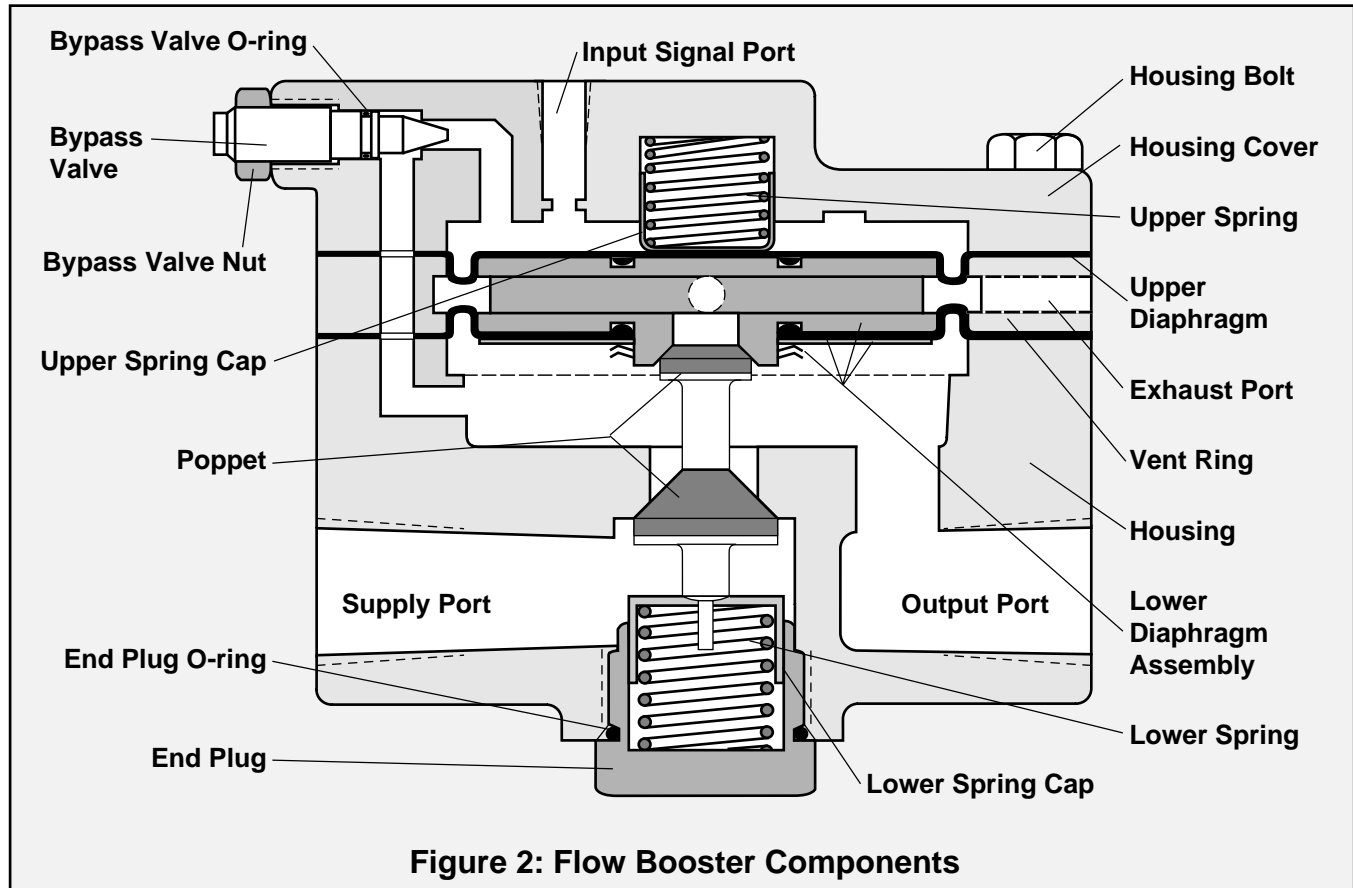

Figure 2: Flow Booster Components

Features	Advantages
Soft-seat sealing	Polyurethane seats provide durability and tight shutoff
One-piece poppet	Unique design eliminates problems associated with an adjustable poppet; flow capacity rated is consistent from one booster to another; fine tuning is not needed for optimal performance
Adjustable response	Bypass valve can be adjusted to eliminate actuator overshoot or over-damping on any size actuator – with or without springs
Fast response	Simple air path minimizes the pressure drop through the booster, increasing the flow capacity; actuators stroke faster than other comparable devices
Simplified maintenance	Simplified design requires fewer parts, providing easy troubleshooting and reassembly
Easy installation / adjustments	Port labels, flow-arrow are cast into the body; bypass valve positioned horizontally and opposite of cylinder for easy accessibility; can be nipple or bracket-mounted
Heavy-duty, corrosion-resistant construction	Anodized aluminum, epoxy powder-painted body provides protection from impact, shocks and corrosive atmospheres

Valtek Flow Booster

Stroking Times

Table I: Stroking Times With and Without Boosters⁽¹⁾

Actuator Size (sq. in.)	Stroke (inches)	Without Boosters		With Boosters	
		Total Time To Open	Total Time To Close	Total Time To Open	Total Time To Close
50 (1/4-inch tubing) ⁽²⁾	1	2.7	1.5	.3	.1
	2	3.7	2.6	.3	.2
	3	4.6	3.6	.4	.3
100 (1/4-inch tubing) ⁽²⁾	2	9.2	5.6	.6	.4
	3	11.1	7.7	.8	.5
	4	12.8	9.6	1.0	.7
	6	15.8	13.0	1.2	.9
	8	18.6	16.2	1.4	1.1
	10	21.2	19.5	1.5	1.4
	12	23.6	22.8	1.7	1.6
	18	29.2	28.9	2.1	2.1
200 (3/8-inch tubing) ⁽²⁾	2	15.2	11.2	1.0	.8
	3	18.9	15.2	1.4	1.1
	4	22.3	18.8	1.7	1.3
	6	28.5	25.1	2.1	1.8
	8	34.3	30.9	2.6	2.3
	10	39.9	36.8	3.0	2.7
	12	45.1	42.6	3.4	3.2
	18	60.0	58.4	4.6	4.5
	24	68.9	68.1	5.3	5.2
300 (3/8-inch tubing) ⁽²⁾	3	26.9	22.9	2.1	1.8
	4	31.9	28.3	2.5	2.3
	6	41.3	37.6	3.3	3.0
	8	50.1	46.1	4.1	3.7
	10	58.5	54.4	4.8	4.4
	12	66.6	62.8	5.6	5.2
	18	89.3	85.9	7.7	7.2
	24	103.1	99.9	9.1	8.6

NOTE: Data is based on tests with boosters connected to the top and bottom ports of a spring cylinder actuator with a fail-close, standard spring and Beta positioner with I/P module, calibrated at 4-20 mA; 80 psi supply air to positioner and boosters.

NOTE: Divide stroking times by two when using two boosters on each cylinder port and 3/4-inch NPT supply air pipes.

(1) Times are in seconds, are estimated and will vary slightly with different packing sets, plug, seals, failure modes, etc.

(2) Listed tubing size is from positioner to actuator on systems without boosters, or to booster input signal on systems with boosters.

All supply air tubing to boosters is 3/4-inch.

Valtek Flow Booster Specifications, Dimensions

Table II: Specifications

Input signal range	Maximum: 150 psig / 11Barg
Supply pressure	Up to 150 psi (check actuator rating)
Ambient temperature limits	-40 to 165 °F -40 to 74 °C
Supply air temperature limits	-40 to 165 °F -40 to 74 °C
Nominal dead band	5.5 percent of input signal span
Connections	Signal - 1/4-inch NPT; Supply - 3/4-inch NPT; Output - 3/4-inch NPT
Maximum C _v	Supply - 5.0; Exhaust - 3.0
Net Weight	Approximately 4.9 lbs

Table III:

Standard Material of Construction

Component	Material
Body	Anodized aluminum
End plug	Nickel plated brass (electroless)
Diaphragm assembly	Anodized aluminum and Buna-N/nylon diaphragms
Poppet	Stainless steel and polyurethane
Needle valve	Stainless steel
Springs	Stainless steel
Spring cap	Stainless steel
Bolts, nuts	Stainless steel

* Booster does not regulate the air. Actuators that use unregulated air must be rated to at least the above pressures, or air must be regulated to actuator rating.

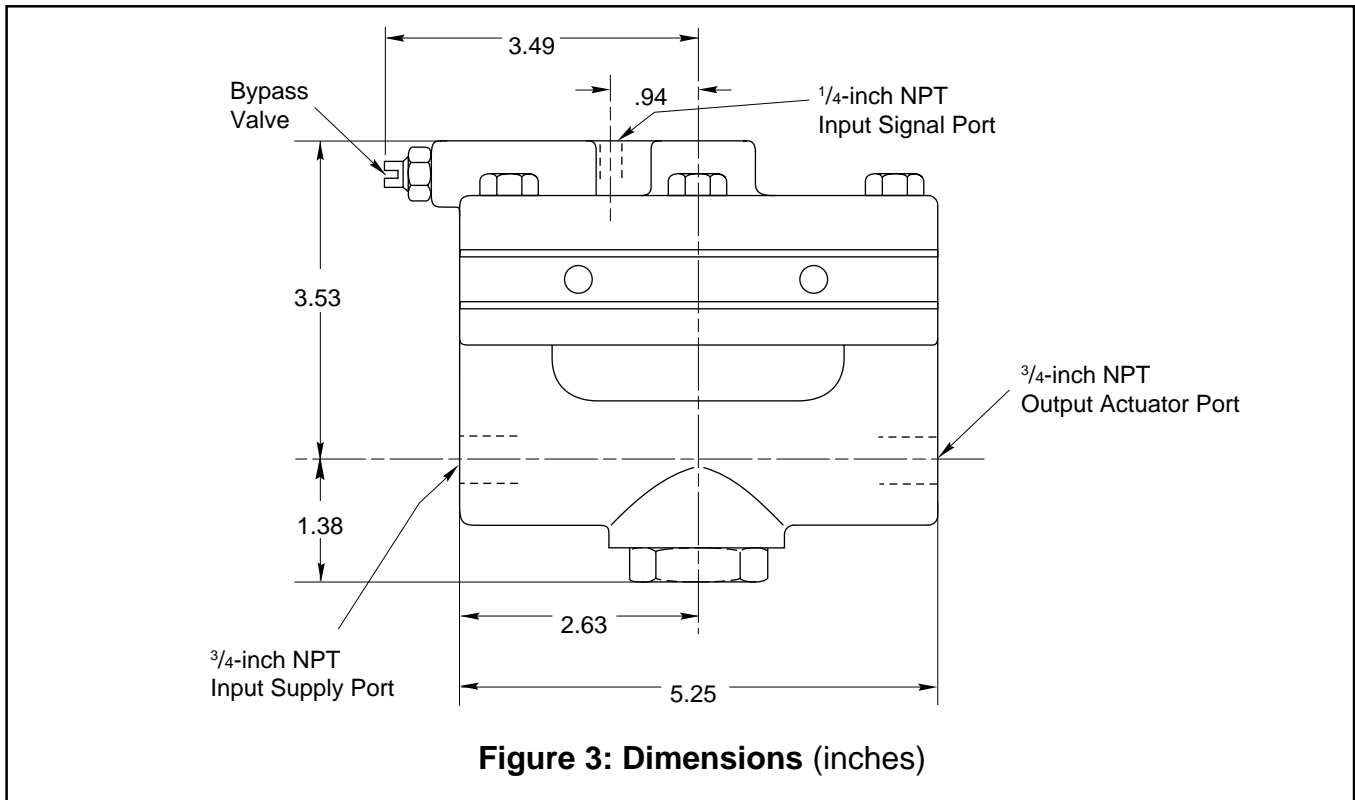

Valtek Flow Booster Schematics

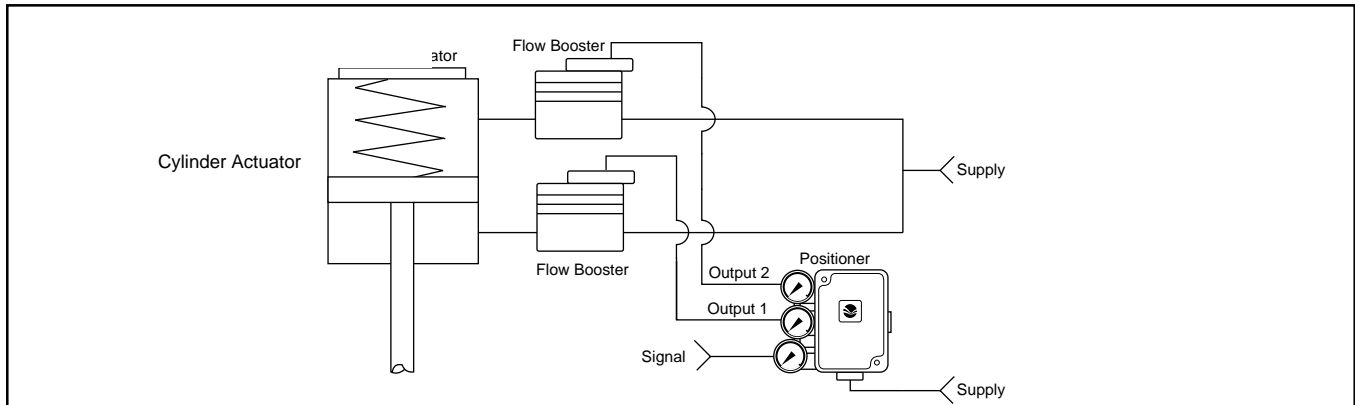

Figure 4: Typical Booster Mounting with Cylinder Actuator

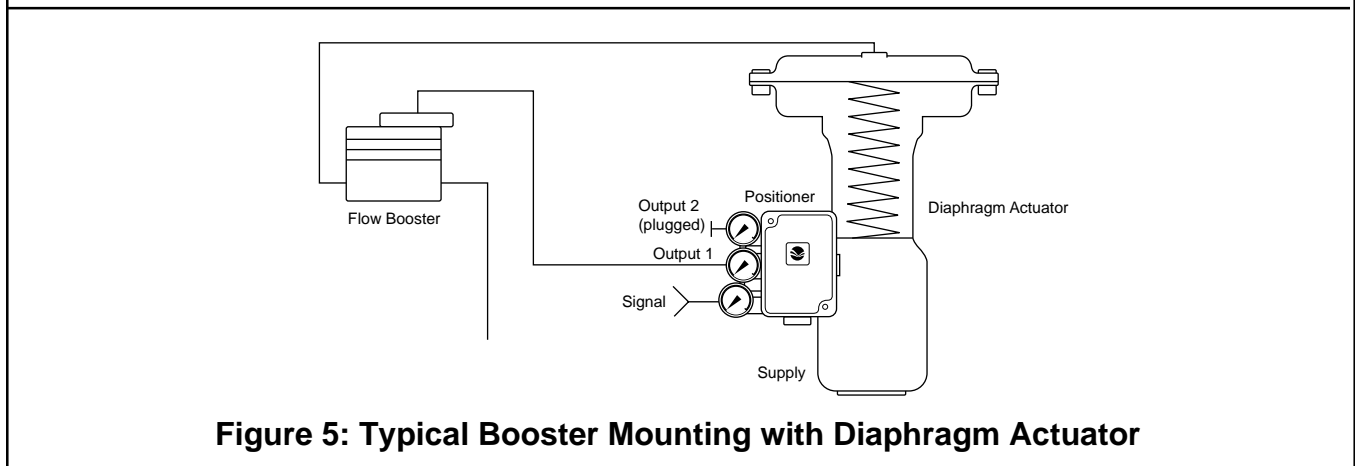

Figure 5: Typical Booster Mounting with Diaphragm Actuator

All Trademarks and trade names shown in this literature are the property of their respective owners.

Flowserve Corporation has established industry leadership in the design and manufacture of its products. When properly selected, this Flowserve product is designed to perform its intended function safely during its useful life. However, the purchaser or user of Flowserve products should be aware that Flowserve products might be used in numerous applications under a wide variety of industrial service conditions. Although Flowserve can (and often does) provide general guidelines, it cannot provide specific data and warnings for all possible applications. The purchaser/user must therefore assume the ultimate responsibility for the proper sizing and selection, installation, operation and maintenance of Flowserve products. The purchaser/user should read and understand the Installation Operation Maintenance (IOM) instructions included with the product, and train its employees and contractors in the safe use of Flowserve products in connection with the specific application.

While the information and specifications presented in this literature are believed to be accurate, they are supplied for informative purposes only and should not be considered certified or as a guarantee of satisfactory results by reliance thereon. Nothing contained herein is to be construed as a warranty or guarantee, express or implied, regarding any matter with respect to this product. Because Flowserve is continually improving and upgrading its product design, the specifications, dimensions and information contained herein are subject to change without notice. Should any question arise concerning these provisions, the purchaser/user should contact Flowserve Corporation at any of its worldwide operations or offices.

For more information, contact:

For more information about Flowserve and its products, contact www.flowserve.com or call USA 972 443 6500

Manufacturing Facilities

1350 N. Mt. Springs Prkwy.
Springville, UT 84663
Phone 801 489 8611
Facsimile 801 489 3719

Allée du Quartz 1
CH-2300 La Chaux-de-Fonds
Switzerland
Telephone (41) 32 925 9700
Facsimile (41) 32 926 5422

Manderscheidstr. 19
45141 Essen, Germany
Telephone (49) 2 01 89 19 5
Facsimile (49) 2 01 891 9600

12, av. du Québec, B.P. 645
91965, Courtaboeuf Cedex,
France
Telephone (33 1) 60 92 32 51
Facsimile (33 1) 60 92 32 99

Quick Response Centers

5114 Railroad Street
Deer Park, TX 77536 USA
Telephone 281 479 9500
Facsimile 281 479 8511

104 Chelsea Parkway
Boothwyn, PA 19061 USA
Telephone 610 497 8600
Facsimile 610 497 6680

1300 Parkway View Drive
Pittsburgh, PA 15205 USA
Telephone 412 787 8803
Facsimile 412 787 1944

